

Current Balance

Theory:

A current-carrying wire in a magnetic field experiences a force that is usually referred to as a magnetic force. The magnitude and direction of this force depend on four variables: the magnitude of the current (**I**); the length of the wire (**L**); the strength of the magnetic field (**B**); and the angle between the field and the wire (**Θ**).

This magnetic force can be described mathematically by the vector cross product:

$$\mathbf{F}_m = \mathbf{IL} \times \mathbf{B},$$

or in a scalar terms,

$$\mathbf{F}_m = ILB\sin \Theta$$

The SF-8607 Basic Current Balance

To set up the Current Balance (see Figure 3):

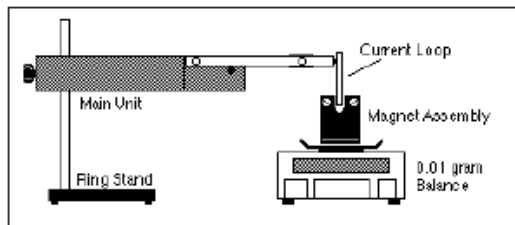

Figure 3 Setting Up the SF-8607 Basic Current Balance

- ① Mount the Main Unit on a lab stand having with a rod 3/8 inch (1.1 cm) in diameter or smaller.
- ② Select a Current Loop, and plug it into the ends of the arms of the Main Unit, with the foil extending down.
- ③ Place the Magnet Assembly on a balance with at least 0.01 gram sensitivity. Position the lab stand so the horizontal portion of the conductive foil on the Current Loop passes through the pole region of the magnets. The Current Loop shouldn't touch the magnets.
- ④ Connect the power supply and ammeter as shown in Figure 4.

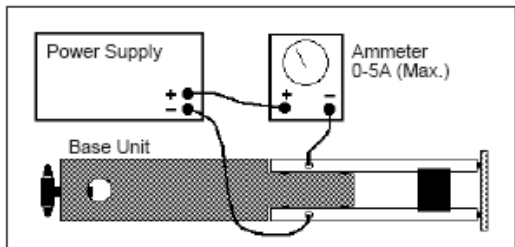

Figure 4 Connecting the Ammeter and Power Supply

Measuring the Force

◆ **Note:** In this manual, we use the balance reading in grams as our measure of force. Most students will realize that the mass reading is proportional to the actual force, which is given by the equation $F = mg$. If you wish to use the actual force value, simply multiply each reading in grams by 0.0098 newtons/gram to arrive at a force in newtons, or by 980 dynes/gram to arrive at a force in dynes.

If you are using a quadruple-beam balance:

First measure the weight of the Magnet Assembly with no current flowing (F_0). Then turn on the current, adjust it to the desired level, and measure the weight of the Magnet Assembly with current flowing (F_1). With current flowing, the reading will be higher or lower than before. The difference in weight ($F_1 - F_0$) is proportional to the force exerted on the magnetic field (and thereby the magnets) by the current-carrying wire. To investigate the relationship between current and force, vary the current and measure the weight at each value.

If you are using a top-loading electronic balance:

With the Magnet Assembly sitting on the balance, tare the reading by pressing the appropriate switch on the balance. This subtracts the weight of the Magnet Assembly from ensuing weight measurements, so only the force caused by the current will be measured. Turn the current on. If the reading is negative, reverse the leads where they plug into the arms of the Main Unit. The measured weight is directly proportional to the force caused by the current moving through the magnetic field.

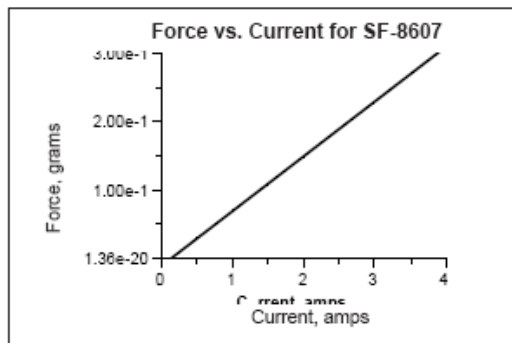

Figure 5 Typical Data for Force versus Current Measurements

Varying the Wire Length

Vary the wire length by using one of the six different Current Loops. To change the Current Loop:

- ① Swing the arm of the Main Unit up, to raise the present Current Loop out of the magnetic field gap. Pull the Current Loop gently from the arms of the base unit. Replace it with a new Current Loop and

carefully lower the arm to reposition the Current Loop in the magnetic field. Six Current Loops are supplied with the SF-8607 Basic Current Balance Kit. The lengths are:

Current Loop	Length
SF 40	1.2 cm
SF 37	2.2 cm
SF 39	3.2 cm
SF 38	4.2 cm
SF 41	6.4 cm
SF 42	8.4 cm

The lengths above were measured at the maximum length of the current-carrying wire foil. The effective length may be somewhat shorter, as much as 0.2 cm for single lengths and 0.4 cm for doubled lengths (doubled lengths refer to Current Loops in which the current passes between the magnet poles twice, once on each side of the PC board).

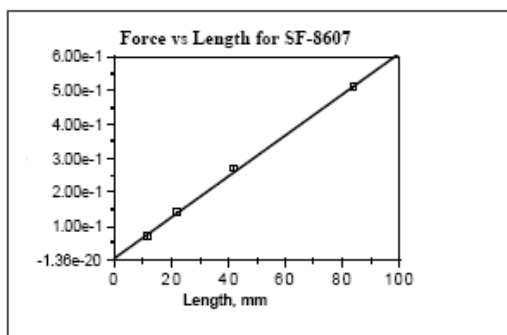

Figure 6 Typical Data for Force versus Wire Length Measurements

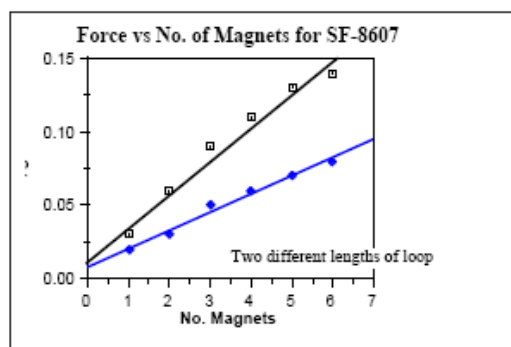

Figure 7 Typical Data for Force versus Wire Length Measurements

Varying the Magnetic Field

The magnetic field is varied by changing the number of magnets that are mounted on the Magnet Assembly. (We recommend you mark the north pole of each magnet, to help students during setup.) The magnetic field strength may not be exactly proportional to the number of magnets, but it is reasonably close, as seen by the data in Figure 7.

SF-8608 Current Balance Accessory

Using the SF-8608 Current Balance Accessory, you can determine how the angle between the current-carrying wire and the magnetic field affects the force between them. The basic experimental setup is shown in Figure 8.

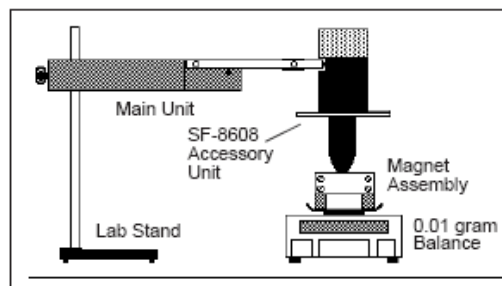

Figure 8 Setup for the SF-8608 Current Balance Accessory.

◆ **Note:** The SF-8608 Current Balance Accessory can also be used to experiment with the relationship between current and force by holding the angle steady and varying the current.

◆ **Warning:** The current through the SF-8608 Current Balance Accessory should never exceed 2.0 amps.

- ① Set the dial on the unit to 0° .
- ② Align the Magnet Assembly so that the magnetic field is approximately parallel with the wires of the coil.
- ③ With the current turned off, measure the weight of the Magnet Assembly, or if you are using an electronic balance, tare the balance.
- ④ Set the current to a value of 2.0 amps. Take a new reading and record this in your data table. Rotate the dial clockwise in 5° increments, taking new readings each at each setting. Then rotate the dial counter-clockwise in 5° increments. The resulting graph of Force vs Angle should be a sine curve.

Experiment 1: Force versus Current

Procedure

If you're using a quadruple-beam balance:

- ① Set up the apparatus as shown in figure 1.1.
- ② Determine the mass of the magnet holder and magnets with no current flowing. Record this value in the column under "Mass" in Table 1.1.
- ③ Set the current to 0.5 amp. Determine the new "mass" of the magnet assembly. Record this value under "Mass" in Table 1.1.
- ④ Subtract the mass value with the current flowing from the value with no current flowing. Record this difference as the "Force."
- ⑤ Increase the current in 0.5 amp increments to a maximum of 5.0 amp, each time repeating steps 2-4.

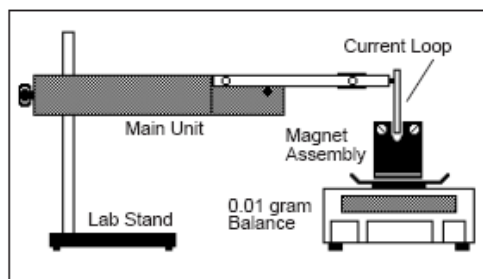

Figure 1.1 Equipment Setup

If you're using an electronic balance:

- ① Set up the apparatus as shown in figure 1.1.
- ② Place the magnet assembly on the pan of the balance. With no current flowing, press the TARE button, bringing the reading to 0.00 grams.
- ③ Now turn the current on to 0.5 amp, and record the mass value in the "Force" column of Table 1.1.
- ④ Increase the current in 0.5 amp increments to a maximum of 5.0 amp, each time recording the new "Force" value.

Data Processing

Plot a graph of Force (vertical axis) versus Current (horizontal axis).

Analysis

What is the nature of the relationship between these two variables? What does this tell us about how changes in the current will affect the force acting on a wire that is inside a magnetic field?

Table 1.1 Data

Current (amps)	"Mass" (gram)	"Force" (gram)	Current (amps)	"Mass" (gram)	"Force" (gram)
0.0			3.0		
0.5			3.5		
1.0			4.0		
1.5			4.5		
2.0			5.0		
2.5					

Experiment 2: Force versus Length of Wire

Procedure

- ① Set up the apparatus as in Figure 2.1.
- ② Determine the length of the conductive foil on the Current Loop. Record this value under "Length" in Table 2.1.

If you are using a quadruple-beam balance:

- ③ With no current flowing, determine the mass of the Magnet Assembly. Record this value on the line at the top of Table 2.1.
- ④ Set the current to 2.0 amps. Determine the new "mass" of the Magnet Assembly. Record this value under "Mass" in Table 2.1.
- ⑤ Subtract the mass that you measured with no current flowing from the mass that you measured with the current flowing. Record this difference as the "Force."
- ⑥ Turn the current off. Remove the Current Loop and replace it with another. Repeat steps 2-5.

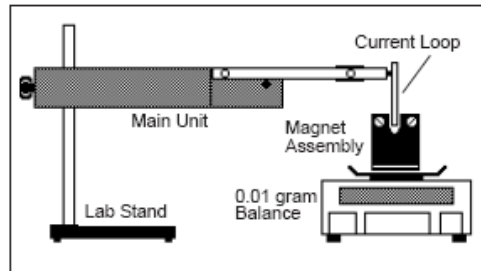

Figure 2.1 Equipment Setup

If you are using an electronic balance:

- ③ Place the magnet assembly on the pan of the balance. With no current flowing, press the TARE button, bringing the reading to 0.00 grams.
- ④ Now turn the current on, and adjust it to 2.0 amps. Record the mass value in the "Force" column of Table 2.1.
- ⑤ Turn the current off, remove the Current Loop, and replace it with another. Repeat steps 2-4.

Data Processing

Plot a graph of Force (vertical axis) versus Length (horizontal axis).

Analysis

What is the nature of the relationship between these two variables? What does this tell us about how changes in the length of a current-carrying wire will affect the force that it feels when it is in a magnetic field?

"Mass" with $I=0$: _____

Table 2.1 Data

Length (mm)	"Mass" (gram)	"Force" (gram)	Length (mm)	"Mass" (gram)	"Force" (gram)

Experiment 3: Force versus Magnetic Field

Procedure

- ① Set up the apparatus as shown in Figure 2.1. Use the shortest length current loop.

If you are using a quadruple-beam balance:

- ② Mount a single magnet in the center of the holder.
- ③ With no current flowing, determine the mass of the Magnet Assembly. Record this value in the first column under "Mass" in Table 3.1 on the appropriate line.
- ④ Set the current to 2.0 amps. Determine the new "mass" of the Magnet Assembly. Record this value in the second column under "Mass" in Table 3.1.
- ⑤ Subtract the mass you measured when there was no current flowing from the value you measured with current flowing. Record this difference as the "Force."
- ⑥ Add additional magnets, one at a time. (Make sure the north poles of the magnets are all on the same side of the Magnet Assembly.) Each time you add a magnet, repeat steps 3-5.

If you use an electronic balance:

- ② Use a single magnet, centered under the center of the holder.
- ③ Place the magnet assembly on the pan of the balance. With no current flowing, press the TARE button, bringing the reading to 0.00 grams.
- ④ Now turn the current on, and adjust it to 2.0 amps. Record the mass value in the "Force" column of Table 3.1.
- ⑤ Add additional magnets, one at a time. (Make sure the north poles of the magnets are all on the same side of the Magnet Assembly.) Each time you add a magnet, repeat steps 3-5.

Data Processing

Plot a graph of Force (vertical axis) versus Number of Magnets (horizontal axis).

Analysis

What is the relationship between these two variables? How does the number of magnets affect the force between a current-carrying wire and a magnetic field? Is it reasonable to assume that the strength of the magnetic field is directly proportional to the number of magnets? What would happen if one of the magnets were put into the assembly backwards, with its north pole next to the other magnets' south poles? If there is time, try it.

Table 3.1 Data

Number of Magnets	"Mass"		"Force" gram	Number of Magnets	"Mass"		"Force" gram
	I = 0 gram	I ≠ 0 gram			I = 0 gram	I ≠ 0 gram	
1				4			
2				5			
3				6			

Experiment 4: Force versus Angle

Procedure

1. Set up the apparatus as shown in Figure 4.1.

If you are using a quadruple-beam balance:

2. Determine the mass of the Magnet Assembly with no current flowing. Record this value in Table 4.1 on the appropriate line.
3. Set the angle to 0° with the direction of the coil of wire approximately parallel to the magnetic field. Set the current to 1.0 amp. Determine the new "mass" of the Magnet Assembly. Record this value under "Mass" in Table 4.1.
4. Subtract the mass measured with no current flowing from the mass measured with current flowing. Record the difference as the "Force."
5. Increase the angle in 5° increments up to 90° , and then in -5° increments to -90° . At each angle, repeat the mass/force measurement.

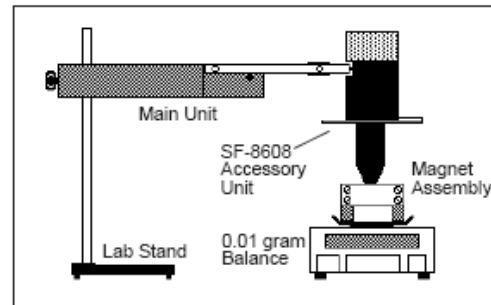

Figure 4.1 Equipment Setup

If you are using an electronic balance:

2. Place the magnet assembly on the pan of the balance. With no current flowing, press the TARE button, bringing the reading to 0.00 grams.
3. Set the angle to 0° with the direction of the coil of wire approximately parallel to the magnetic field. Set the current to 1.0 amp. Record the mass value in the "Force" column of Table 4.1.
4. Increase the angle in 5° increments up to 90° , and then in -5° increments to -90° . At each angle, repeat the mass/force measurement.

Data Processing

Plot a graph of Force (vertical axis) versus Angle (horizontal axis).

Analysis

What is the relationship between these two variables? How do changes in the angle between the current and the magnetic field affect the force acting between them? What angle produces the greatest force? What angle produces the least force?

Table 4.1 Data

"Mass" with $I = 0$: _____

Angle (θ)	"Mass" (gram)	"Force" (gram)	Angle (θ)	"Mass" (gram)	"Force" (gram)	Angle (θ)	"Mass" (gram)	"Force" (gram)	Angle (θ)	"Mass" (gram)	"Force" (gram)
0			50			0			-50		
5			55			-5			-55		
10			60			-10			-60		
15			65			-15			-65		
20			70			-20			-70		
25			75			-25			-75		
30			80			-30			-80		
35			85			-35			-85		
40			90			-40			-90		
45						-45					